

LTC Veloce-Square 60w



 **Product Overview**

Energy efficient & cost effective luminaire suitable for any kind of industrial LED lighting application

- IP65 Optical chamber
- Glare free optimized light distribution
- Standard warranty: 3 years *(Extended warranty of up to 2 years*)
- Thermal cut-out & short circuit protection

 **Product Applications**

- Manufacturing Plants
- Food Industry
- Pharmaceuticals
- Factories & Processing Plants
- General Industrial
- Gas Stations
- Canopy Lighting
- Warehouse & Distribution Centers & many more...





Main Features

Product Name:	LTC Veloce-Square 60w
AC Input:	100-270V, 47/63Hz
LED:	Nichia
CRI Range:	CRI>80
CCT Range:	4500~5500K (2500~5500K optional)
Luminous Flux:	9000 lm
Power Options:	60W±5W
Beam Angle:	120 Deg
Size:	L350mm*W350mm*H50mm
IP Rating:	IP65

Light Distribution

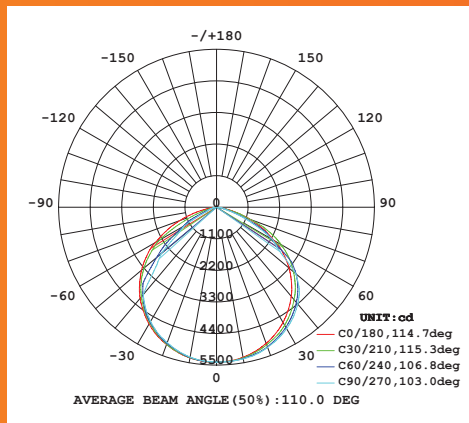

Physical Dimensions

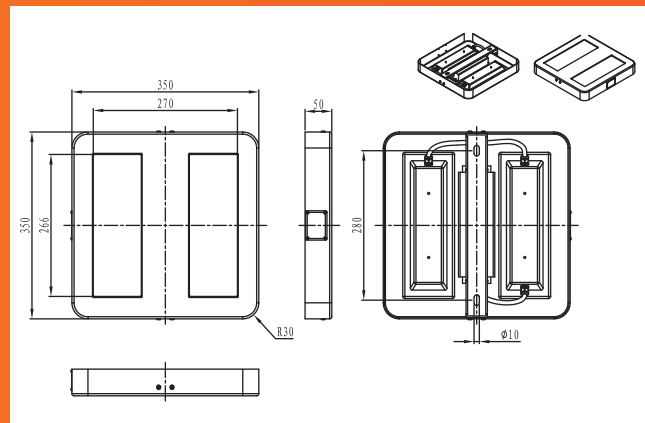

Contact Us

LTC Head Office:

Sales: 1300 832 372

Email: sales@lighttc.com.au

Admin: 1300 832 372

Email: admin@lighttc.com.au

Website: www.lighttc.com.au



Address:

251 Rawson Street,
Auburn, NSW. 2144. Australia.