

LTC
Veloce-Square



**32,000
Lumens**

Product Overview

Energy efficient & cost effective luminaire suitable for any kind of industrial LED lighting application

- » IP65 Optical chamber
- » Thermal rating: 50°C (Remote driver)
30°C (Integral driver)
- » Glare free optimized light distribution
- » Housing: High grade zinc steel white powder coated

Product Applications

- Manufacturing Plants
- Food Industry
- Pharmaceuticals
- Factories & Processing Plants
- General Industrial
- Gas Stations
- Canopy Lighting
- Warehouse & Distribution Centers & many more...

- » Standard warranty: 5 years replacement warranty
- » Thermal cut-out & short circuit protection
- » Emergency options & a wide variety of control system add-ons
- » Suitable for 600mm x 600mm cut-outs



Main Features

Product Name:	LTC Veloce-Square
AC Input:	220-240V, 50/60Hz
LED & Driver:	Luxeon & Meanwell
CRI Range:	CRI>80
CCT Range:	5000K (4000K, 5500K optional)
Luminous Flux:	19,647Lm (150W), 26,253Lm (200W), 30,595.2Lm (240W), 32,124.9Lm* (240W)
Power Options:	150W to 240W
Temperature Rating:	50°C (Remote driver) 30°C (Integral driver)
Mounting Options:	Surface mounted (or Recess mounted with recess mounting kit)
Emergency Options:	Manual Test, Self-Test & Monitored
Accessories:	Recess mounting flanges (Optional)

*optional

LTC Veloce-Square

Ergonomic and smart design for any kind of recess or surface mounted application including one to one LED retrofitting of existing HID lights

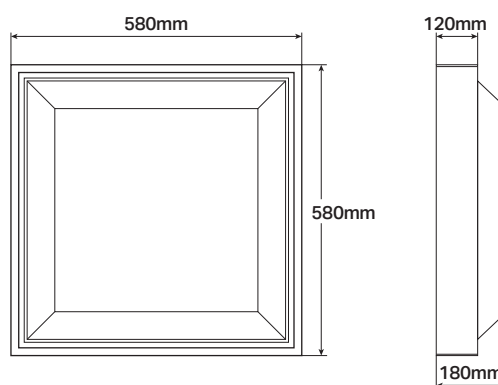

Contact Us

LTC Head Office:

Sales: 1300 832 372

Email: sales@lighttc.com.au

Admin: 1300 832 372

Website: www.lighttc.com.au



Address:

251 Rawson Street,
Auburn, NSW 2144, Australia